



since 1977

Your comfort. Your safety.

PIASTRA GIREVOLE SWIVEL PLATE



▼ P/N: 9PG0147501V01



PEUGEOT Expert

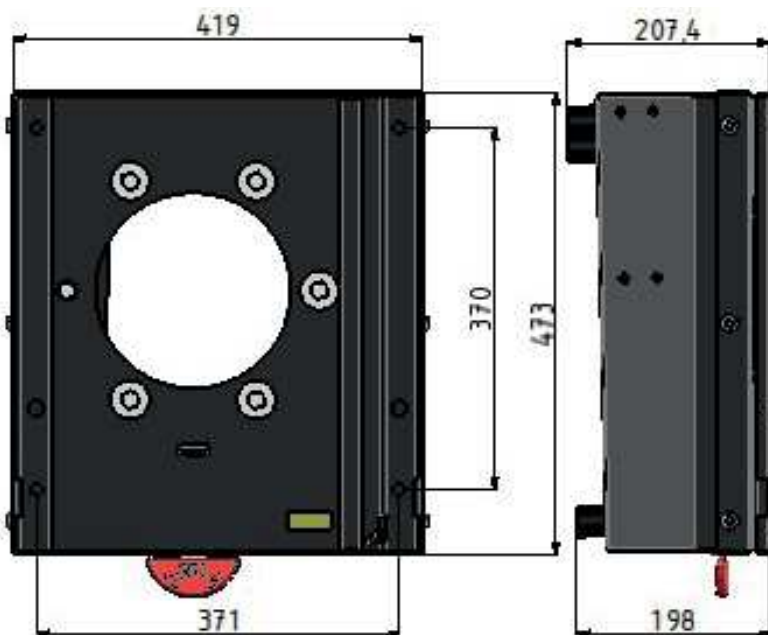

Piastra girevole per sedile originale compatibile con modelli specificati. Design compatto e resistente, rotazione fluida, peso contenuto. Versione lato Guidatore EU e Passeggero UK.

Quando la piastra viene montata sul lato Guidatore va utilizzato il kit decentramento freno a mano "P/N 9PG0147600V01" per consentire la rotazione del sedile senza che ci sia interferenza tra il sedile e la leva freno a mano.

La piastra girevole è compatibile sia con il sedile meccanico che con sedile elettrico.

Swivel plate for original cabin chassis, compatible with chassis models specified. Compact, high resistant design, smooth rotation system, lightweight. Driver's side version EU and Passenger version UK.

When the swivel plate is mounted on the driver's side, the handbrake decentralization kit "9PG0147600V01" must be used to allow the seat to rotate without interference between the seat and the handbrake lever.

The swivel plate is compatible with both mechanical and power seats.

DATI TECNICI/Technical Datasheet

Dimensioni/Dimension	419x473x198-207,4 mm		
Peso/Weight	12,8 kg		
Materiale/Materials	Acciaio/Steel		
Trattamento/Treatment	Verniciato/Painted		
Colore/Colours	Nero/Black		
R14	PEUGEOT Expert	from 2016 - YTD	Compatible with Peugeot Traveller from 2016 - YTD

	Citroen Jumpy / Space-Tourer from 2016 - YTD
	Citroen Dispatch (UK) from 2016 - YTD
	Opel Vivaro / Zafira Life from 2019 - YTD
	Vauxhall Vivaro (UK) from 2019 - YTD
	Toyota ProAce II from 2016 - YTD
	Fiat Scudo from 2022 - YTD
	Fiat Ulysse from 2022 - YTD

NOTA: per veicoli elettrici/ibridi con batterie sotto i sedili, le piastre girevoli non sono compatibili.

NOTE: for electrical/hybrid vehicles with batteries under the seats, the swivel plates are not compatibles

Prima dell'installazione verificare eventuali interferenze che impediscono il corretto funzionamento del sistema, eventuali modifiche rimangono a carico dell'allesitore.

Before installation, check for any interferences that prevent the correct functioning of the system, any modifications are the responsibility of the bodybuilder.

Rev. 05
03/12/2024



CTA S.R.L.

Via Nicaragua 4 • 00071 Pomezia (RM) Italy • Tel. - Fax 06.91601096

www.cta-europe.com

info@cta-europe.com