



since 1977

Your comfort. Your safety.

# PIASTRA GIREVOLE SWIVEL PLATE



▼ P/N: 9PG0085800V01  VOLKSWAGEN Transporter T5-T6

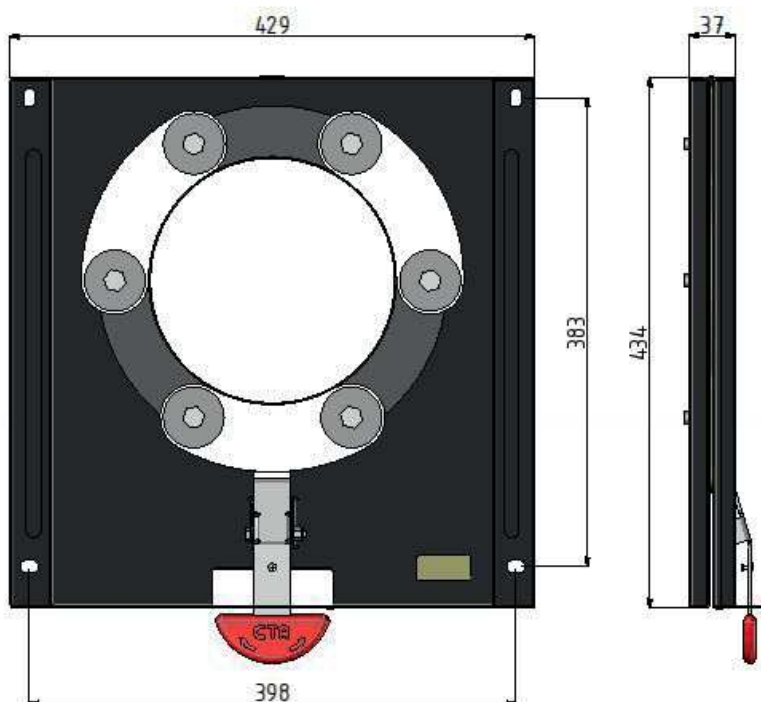

Design compatto e resistente, rotazione fluida, peso contenuto. Versione universale Dx – Sx. Quando la piastra girevole viene montata sul lato Guida- tore va utilizzato il kit decentramento per il freno a mano “P/N 9PG0121800V01” versione EU e “P/N 9PG0121803V01” versione UK, per evitare interferenze tra sedile e leva durante la rotazione.

*Compact and durable design, smooth rotation, light weight. Universal Right - Left version. When the swivel plate is mounted on the Driver's side, the off-center handbrake kit “P/N 9PG0121800V01 ‘EU version and ‘P/N 9PG0121803V01 “UK version should be used to avoid interference between seat and lever during rotation.*

## DATI TECNICI/Technical Datasheet

Dimensioni/Dimension	429x434x37 mm
Peso/Weight	7,3 kg
Materiale/Materials	Acciaio-Plastica/Steel-Plastic
Trattamento/Treatment	Verniciato/Powder coating
Colore/Colours	Nero/Black
R14-R17	 VOLKSWAGEN Transporter T5 - T6
	from 2003 - 2023

NOTA: per veicoli elettrici/ibridi con batterie sotto i sedili, le piastre girevoli non sono compatibili.

NOTE: for electrical/hybrid vehicles with batteries under the seats, the swivel plates are not compatibles

Prima dell'installazione verificare eventuali interferenze che impediscono il corretto funzionamento del sistema, eventuali modifiche rimangono a carico dell'allestitore.

Before installation, check for any interferences that prevent the correct functioning of the system, any modifications are the responsibility of the bodybuilder.



Your comfort. Your safety.

CTA S.R.L.

Via Nicaragua 4 • 00071 Pomezia (RM) Italy • Tel. - Fax 06.91601096



www.cta-europe.com



info@cta-europe.com